

NOA SYSTEM

208-191c6122

left right, XTSC 612-2

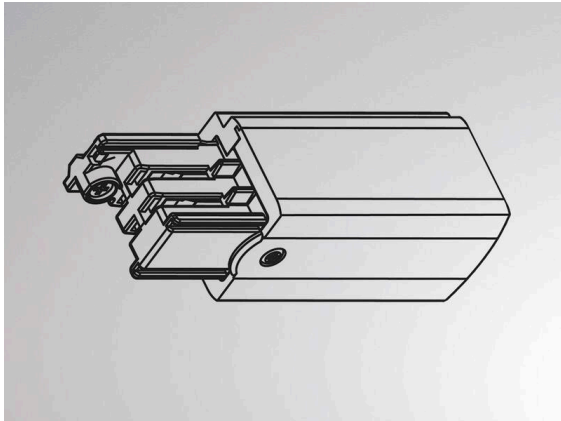

SKETCH

TECHNICAL DETAILS

Dimmability	DALI
Voltage	220-240V 50/60Hz
Length [mm]	90
Width [mm]	31,5
IP protection class	IP20
IP protection class	protection cl. I
Material	synthetic
Colour of body	black
RAL	9005
Net weight [kg]	0.07
EAN number	6410014532413

Schutzleiter links / Earth left



The values are rated values. Power and luminous flux are initially subject to a tolerance of +/- 10%.
Colour temperature tolerance: +/- 150 K. The values apply to an ambient temperature of 25°C unless otherwise specified.